

CONNECTOR SELECTION GUIDE



FOR USE WITH PRODUCTS
MANUFACTURED BY:



This guide lists popular options for Simpson Strong-Tie® hangers used with engineered wood products. Not all available hanger and installation combinations are listed. Use in conjunction with the current Simpson Strong-Tie Canadian **Wood Construction Connectors** catalogue for detailed hanger information.



LIMIT
STATES
DESIGN

800-999-5099
www.strongtie.com

DISTRIBUTED BY:

General Notes

- See current Canadian *Wood Construction Connectors* catalogue for Important Information and General Notes section and for hanger models, joist sizes, and header situations not shown. See pages 10-11 for installation information.
- Unless otherwise noted, factored resistances (downloads) listed address hanger/header/fastener limitations assuming header material is Douglas Fir-Larch, Spruce Pine Fir, Microllam® LVL, Parallam® PSL, or Timber-Strand® LSL. Joist reaction should be checked by a qualified designer to ensure proper hanger selection.
- Factored uplift resistances (uplift) listed assume SPF joist and header and have been increased by 15% for earthquake and wind loading with no further increase allowed. Reduce loads according to code for normal duration loading such as cantilever construction.
- If hanger height is less than 60% of joist height, joist rotation may occur; see Prevent Rotation information below.
- Top flange hanger configuration and thickness of top flange need to be considered for flush frame conditions, see page 10.
- For this publication, carrying members are assumed to be at least 5½" tall. The horizontal thickness of the carrying member must be at least the length of nail being used or the hanger top flange dimension, whichever is greater.
Exception: narrower carrying members may be used with face mount hangers but the horizontal thickness must be at least 1¾" for 10d nails; 2" for 16d nails. Clinch nails on back side.
- THAI hangers in this publication are based on a "top flange" installation and require that the carrying member have a horizontal thickness of at least 2½". Backer blocks are required when the header is an TJI® Joist.
- All nails shown are common nails unless otherwise noted.
- TJI® Joists that are used as headers require backer blocks. See TJI® Joist Headers below for additional information.
- Multiple Members:** Multiple members should be adequately connected together to act as one unit.

TJI® Joist Headers

TJI® Joist Headers: When supporting one TJI® Joist from another, backer blocks must be used. Backer blocks are to be made from plywood, OSB, or dimension lumber. The thickness of a backer block should be the same thickness as the void in the side of the TJI® Joist and a minimum of 12" wide. Attach with 10-10d common nails clinched as necessary, prior to installing the hanger. For Top Flange hangers, install backer blocks tight to top flange. For Face Mount hangers, install backer blocks tight to bottom flange. Refer to iLevel® TJI® Joist literature for specific guidelines.

Use 10dx1½" nails for all Top Flange hangers attached to an TJI® Joist header. See table for allowable loads.

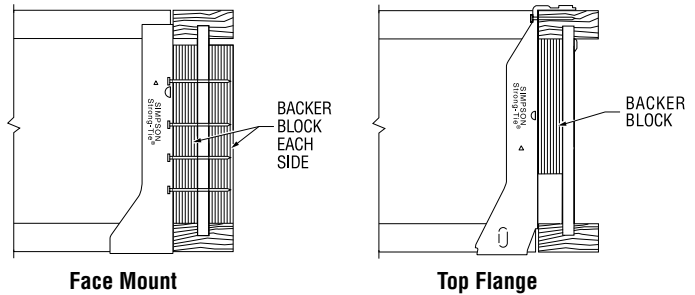

Model	I-Joist Header Flange Material¹	
	DF/SCL	SPF
ITS	1375	1375
LT	1695	1695
MIT	1900	1900
LBV	2200	2200
BA	2420	2420

- For flanges with thicknesses from 1⅞" to 1⅝", use 0.85 of the TJI® Joist header load. For flanges with thicknesses of 1¼", use 0.75 of the TJI® Joist header load.

Sloped Joists: For joists sloped up to ¼:12, regular (non-sloped) hangers may be used at full load value. For slopes greater than ¼:12, see adjacent table.

Sloped Joist		
Model	Slope	Reduction
All Models	up to ¼:12	no reduction
ITS, IUS, LT, LF, MIT, MIU, LBV, B, HB	up to ½:12	10%
WP, HW	up to ¾:12	15%

For face mount hangers using 10d nails with headers less than 1¾" wide horizontally but at least 1½" wide, apply a reduction factor of 0.77 to all table loads.

Prevent Rotation

Hangers provide some joist rotation resistance; however, additional lateral restraint may be required for deep joists.

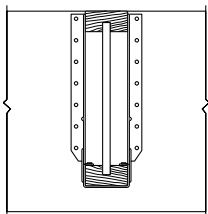

No Web Stiffener Installed
Hanger side flange supports joist top flange.

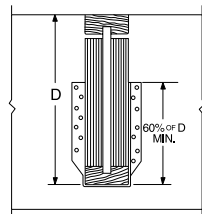

Web Stiffener Required
Hanger side flange should be at least 60% of joist depth or potential joist rotation must be addressed.

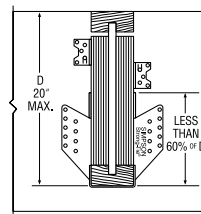

Rotation Resistance
If non-skewed hanger side flange is less than 60% of joist depth, attach staggered A34 framing anchors above the hanger.

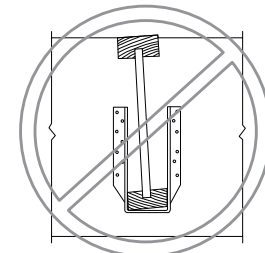

No Web Stiffener Results in Rotation
Hanger side flange is below the joist top flange. No web stiffener results in rotation, unless restrained by other means.

HOW TO PICK A HANGER

Follow these simple steps to choose your hanger:

1	Find your TJI® Joist size in this guide.
2	Choose your header type. Solid header or TJI® Joist. <ul style="list-style-type: none">• Solid headers include solid sawn Douglas Fir, Spruce-Pine Fir, and iLevel® Microllam® LVL, Parallam® PSL, or TimberStrand® LSL.• For TJI® Joist headers see page 2.
3	Locate your connector type in the table. <ul style="list-style-type: none">• Face mount, top flange, skewed, sloped, etc.
4	Select a hanger from the table.
5	Confirm that your factored joist reaction is less than the factored resistance of hanger. If yes, you have successfully selected your hanger.
	If you did not find a suitable hanger; Please see the current Canadian <i>Wood Construction Connectors</i> catalogue or call Simpson Strong-Tie at (800) 999-5099. You will need the following information: <ul style="list-style-type: none">• Download• Uplift• Header condition• Bearing length requirement

SINGLE TJI® JOISTS – Canadian/Factored Resistance (lbs)



Joist Height	Top Flange							Face Mount (Snap-In)						Face Mount							
	Model	B Dim	Fastener Type		Uplift (115)	Download		Model	B Dim	Fastener Type		Uplift (115)	Download		Model	B Dim	Fastener Type		Uplift (115)	Download	
			Header	Joist		DF	SPF			Header	Joist		DF	SPF			Header	Joist		DF	SPF
TJI® 110																					
Joist Width = 1¾"																					
9½	LT179	2	6-10d	1-#8x1¼ WS	100	2560	1725	IUS1.81/9.5	2	8-10d	—	145	2385	1700	LF179	2	10-10d	1-#8x1¼ WS	100	2525	2155
11⅞	LT171188	2	6-10d	1-#8x1¼ WS	100	2560	1725	IUS1.81/11.88	2	10-10d	—	145	2565	1835	LF1711	2	12-10d	1-#8x1¼ WS	100	2840	2155
14	LT1714	2	6-10d	1-#8x1¼ WS	100	2560	1725	IUS1.81/14	2	12-10d	—	145	2565	1835	LF1714	2	14-10d	1-#8x1¼ WS	100	2840	2155
TJI® 210																					
Joist Width = 2¼"																					
9½	ITS2.06/9.5	2	6-10d	—	125	2235	1690	IUS2.06/9.5	2	8-10d	—	145	2385	1700	See Canadian <i>Wood Construction Connectors</i> catalogue for hanger selection.						
11⅞	ITS2.06/11.88	2	6-10d	—	125	2235	1690	IUS2.06/11.88	2	10-10d	—	145	2565	1835							
14	ITS2.06/14	2	6-10d	—	125	2235	1690	IUS2.06/14	2	12-10d	—	145	2565	1835							
16	LBV2.1/16	2½	10-16d	2-10dx1½	310	3905	3125	IUS2.06/16	2	14-10d	—	145	2725	1950							
TJI® 230																					
Joist Width = 2¾"																					
9½	LT239	2	6-10d	1-#8x1¼ WS	100	2560	1725	IUS2.37/9.5	2	8-10d	—	145	2385	1700	LF239	2	10-10d	1-#8x1¼ WS	100	2525	2155
11⅞	LT231188	2	6-10d	1-#8x1¼ WS	100	2560	1725	IUS2.37/11.88	2	10-10d	—	145	2565	1835	LF2311	2	12-10d	1-#8x1¼ WS	100	2880	2270
14	LT2314	2	6-10d	1-#8x1¼ WS	100	2560	1725	IUS2.37/14	2	12-10d	—	145	2565	1835	LF2314	2	14-10d	1-#8x1¼ WS	100	3225	2385
16	LT2316	2	6-10d	1-#8x1¼ WS	100	2560	1725	IUS2.37/16	2	14-10d	—	145	2725	1950	MIU2.37/16	2½	24-16d	2-10dx1½	375	4695	3485
TJI® 360																					
Joist Width = 2¾"																					
9½	LT239	2	6-10d	1-#8x1¼ WS	100	2560	1725	IUS2.37/9.5	2	8-10d	—	145	2385	1700	LF239	2	10-10d	1-#8x1¼ WS	100	2525	2155
11⅞	LT231188	2	6-10d	1-#8x1¼ WS	100	2560	1725	IUS2.37/11.88	2	10-10d	—	145	2565	1835	LF2311	2	12-10d	1-#8x1¼ WS	100	2880	2270
14	LT2314	2	6-10d	1-#8x1¼ WS	100	2560	1725	IUS2.37/14	2	12-10d	—	145	2565	1835	LF2314	2	14-10d	1-#8x1¼ WS	100	3225	2385
16	LT2316	2	6-10d	1-#8x1¼ WS	100	2560	1725	IUS2.37/16	2	14-10d	—	145	2725	1950	MIU2.37/16	2½	24-16d	2-10dx1½	375	4695	3485
18	MIT3518	2½	8-16d	2-10dx1½	535	3480	2415	No IUS hangers for these depths.						MIU2.37/18	2½	26-16d	2-10dx1½	375	4695	3485	
20	MIT3520	2½	8-16d	2-10dx1½	535	3480	2415							MIU2.37/20	2½	28-16d	2-10dx1½	375	4695	3485	
TJI® 560																					
Joist Width = 3½"																					
9½	LT359	2	6-10d	2-#8x1¼ WS	100	2560	1725	IUS3.56/9.5	2	10-10d	—	145	2375	1695	LF359	2	10-10d	2-#8x1¼ WS	100	2525	2155
11⅞	LT351188	2	6-10d	2-#8x1¼ WS	100	2560	1725	IUS3.56/11.88	2	12-10d	—	145	2375	1695	LF3511	2	12-10d	2-#8x1¼ WS	100	2880	2270
14	LT3514	2	6-10d	2-#8x1¼ WS	100	2560	1725	IUS3.56/14	2	12-10d	—	145	2375	1695	LF3514	2	14-10d	2-#8x1¼ WS	100	3235	2385
16	LT3516	2	6-10d	2-#8x1¼ WS	100	2560	1725	IUS3.56/16	2	14-10d	—	145	2375	1695	MIU3.56/16	2½	24-16d	2-10dx1½	375	4930	3485
18	MIT418	2½	8-16d	2-10dx1½	535	3480	2415	No IUS hangers for these depths.						MIU3.56/18	2½	26-16d	2-10dx1½	375	4930	3485	
20	MIT420	2½	8-16d	2-10dx1½	535	3480	2415							MIU3.56/20	2½	28-16d	2-10dx1½	375	4930	3485	

- Shaded hangers require web stiffeners at joist ends. Web stiffeners may be required by others for non-shaded hangers.
- THAI hangers require a minimum of 4 top and 2 face nails installed. (See note 7, page 2)
- See page 2, note 2 for header definitions.
- WS = wood screw.

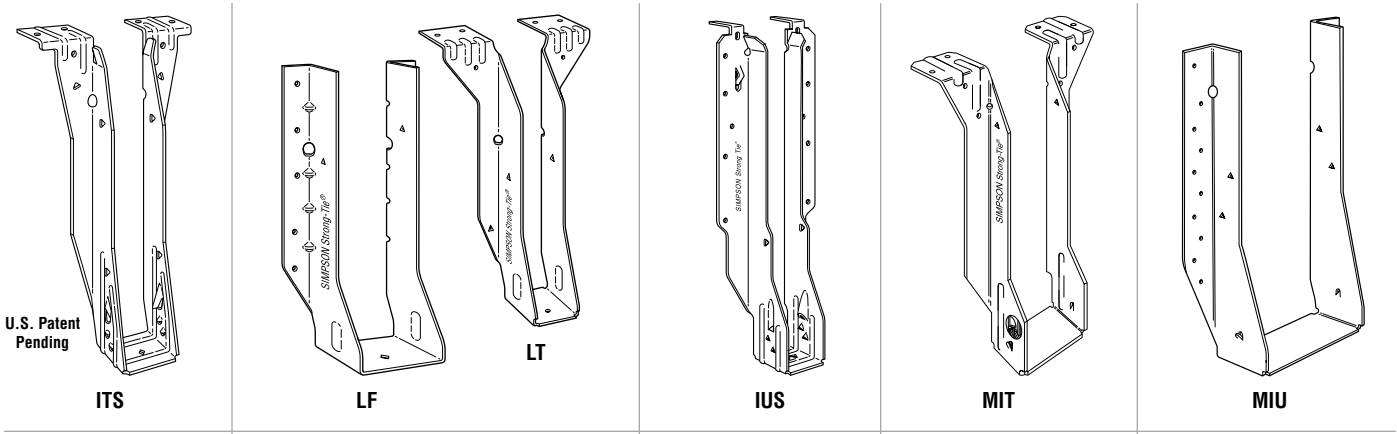

ITS – 18 gauge
The new ITS top flange hanger with its Strong-Grip™ seat and Funnel Flange™ installs faster than any other top flange hanger. Joist nails are not required.

LF – 18 gauge
LT – 18 gauge
The LF and LT series feature fast and easy installation. No web stiffeners required and only one screw secures joist in hanger.

IUS – 18 gauge
The IUS is a new hybrid hanger that incorporates the advantages of face-mount and top-flange hangers. Joist nails are not required.

MIT – 16 gauge
The MIT's Positive Angle Nailing helps prevent the TJI® Joist bottom flange from splitting. Features uplift capacity and extended seat design (to allow installation of slightly undercut joists).

MIU – 16 gauge
The MIU series features 16 gauge steel and extra nailing for higher loads than the LF.

SINGLE TJI® JOISTS – Canadian/Factored Resistance (lbs)



Joist Height	Adjustable Height							Field Slope & Skew							45° Skew									
	Model	B Dim	Fastener Type			Uplift (115)	Download		Model	B Dim	Fastener Type		Uplift (115)	Download		Model	B Dim	Fastener Type		Uplift (115)	Download			
			Header	Joist	2-10dx1½		DF	SPF			Header	Joist		7-10dx1½	DF			SPF	Header		Joist	2-10dx1½	DF	SPF
TJI® 110																								
Joist Width = 1¾"																								
9½	THAI1.81/22	2¼	4-10d	2-10d	2-10dx1½	—	2740	2075	LSSUI25	3½	9-10d	7-10dx1½	1285	2090	1495	SUR/L1.81/9	3	12-16d	2-10dx1½	275	3140	2220		
11⅞	THAI1.81/22	2¼	4-10d	2-10d	2-10dx1½	—	2740	2075	LSSUI25	3½	9-10d	7-10dx1½	1285	2090	1495	SUR/L1.81/11	3	16-16d	2-10dx1½	275	3140	2220		
14	THAI1.81/22	2¼	4-10d	2-10d	2-10dx1½	—	2740	2075	LSSUI25	3½	9-10d	7-10dx1½	1285	2090	1495	SUR/L1.81/14	3	20-16d	2-10dx1½	275	3140	2220		
TJI® 210																								
Joist Width = 2⅞"																								
9½	THAI2.1/22	2¼	4-10d	2-10d	2-10dx1½	—	2740	2075	LSSU2.1	3½	9-10d	7-10dx1½	1285	2090	1495	SUR/L2.1/9	3⅞	14-16d	2-10dx1½	385	3945	2780		
11⅞	THAI2.1/22	2¼	4-10d	2-10d	2-10dx1½	—	2740	2075	LSSU2.1	3½	9-10d	7-10dx1½	1285	2090	1495	SUR/L2.1/11	3⅞	16-16d	2-10dx1½	385	3945	2780		
14	THAI2.1/22	2¼	4-10d	2-10d	2-10dx1½	—	2740	2075	LSSU2.1	3½	9-10d	7-10dx1½	1285	2090	1495	SUR/L2.1/11	3⅞	16-16d	2-10dx1½	385	3945	2780		
16	See Canadian Wood Construction Connectors catalogue for hanger selection.								See Canadian Wood Construction Connectors catalogue for hanger selection.								SUR/L2.1/11	3⅞	16-16d	2-10dx1½	385	3945	2780	
TJI® 230																								
Joist Width = 2⅞"																								
9½	THAI3522	2¼	4-10d	2-10d	2-10dx1½	—	2740	2075	LSSUI35	3½	9-10d	7-10dx1½	1285	2090	1495	SUR/L2.37/9	3⅞	14-16d	2-10dx1½	385	3945	2780		
11⅞	THAI3522	2¼	4-10d	2-10d	2-10dx1½	—	2740	2075	LSSUI35	3½	9-10d	7-10dx1½	1285	2090	1495	SUR/L2.37/11	3⅞	16-16d	2-10dx1½	385	3945	2780		
14	THAI3522	2¼	4-10d	2-10d	2-10dx1½	—	2740	2075	LSSUI35	3½	9-10d	7-10dx1½	1285	2090	1495	SUR/L2.37/14	3⅞	18-16d	2-10dx1½	385	3945	2780		
16	See Canadian Wood Construction Connectors catalogue for hanger selection.								See Canadian Wood Construction Connectors catalogue for hanger selection.								SUR/L2.37/14	3⅞	18-16d	2-10dx1½	385	3945	2780	
TJI® 360																								
Joist Width = 2⅞"																								
9½	THAI3522	2¼	4-10d	2-10d	2-10dx1½	—	2740	2075	LSSUI35	3½	9-10d	7-10dx1½	1285	2090	1495	SUR/L2.37/9	3⅞	14-16d	2-10dx1½	385	3945	2780		
11⅞	THAI3522	2¼	4-10d	2-10d	2-10dx1½	—	2740	2075	LSSUI35	3½	9-10d	7-10dx1½	1285	2090	1495	SUR/L2.37/11	3⅞	16-16d	2-10dx1½	385	3945	2780		
14	THAI3522	2¼	4-10d	2-10d	2-10dx1½	—	2740	2075	LSSUI35	3½	9-10d	7-10dx1½	1285	2090	1495	SUR/L2.37/14	3⅞	18-16d	2-10dx1½	385	3945	2780		
16	See Canadian Wood Construction Connectors catalogue for hanger selection.								See Canadian Wood Construction Connectors catalogue for hanger selection.								SUR/L2.37/14	3⅞	18-16d	2-10dx1½	385	3945	2780	
18																	SUR/L2.37/14	3⅞	18-16d	2-10dx1½	385	3945	2780	
20																	SUR/L2.37/14	3⅞	18-16d	2-10dx1½	385	3945	2780	
TJI® 560																								
Joist Width = 3½"																								
9½	THAI422	2¼	4-10d	2-10d	2-10dx1½	—	2740	2075	LSSU410	3½	14-16d	12-10dx1½	1725	3055	2160	SUR/L410	2½	14-16d	6-16d	1975	4065	2875		
11⅞	THAI422	2¼	4-10d	2-10d	2-10dx1½	—	2740	2075	LSSU410	3½	14-16d	12-10dx1½	1725	3055	2160	SUR/L410	2½	14-16d	6-16d	1975	4065	2875		
14	THAI422	2¼	4-10d	2-10d	2-10dx1½	—	2740	2075	LSSU410	3½	14-16d	12-10dx1½	1725	3055	2160	SUR/L414	2½	18-16d	8-16d	2175	4095	2895		
16	See Canadian Wood Construction Connectors catalogue for hanger selection.								See Canadian Wood Construction Connectors catalogue for hanger selection.								SUR/L414	2½	18-16d	8-16d	2175	4095	2895	
18																	SUR/L414	2½	18-16d	8-16d	2175	4095	2895	
20																	SUR/L414	2½	18-16d	8-16d	2175	4095	2895	

1. See footnotes on page 4.

Specified Nail	CSA 086-01 Nail
8d	2½" common wire
10d	3" common wire
16d	3½" common wire

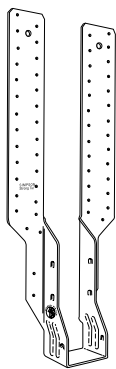

THAI

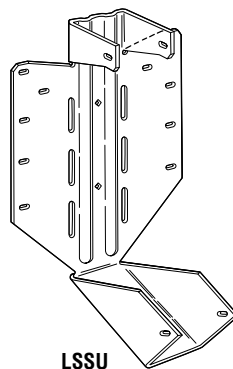

LSSU

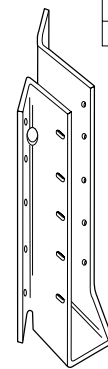

SUR

THAI – 18 gauge
This hanger has extra long straps and can be field-formed to give height adjustability and top flange hanger convenience. Positive angle nailing helps minimize splitting of the TJI® Joist's bottom flange. Minimum nailing is shown in the table above. Strap must be field-formed over the top of the header by a minimum of 2½". Web stiffeners required when used with I-joists.

LSSU, LSSUI – 18 gauge
LSSU210-2, LSSU410, and LSSUH310 – 16 gauge
LSU – 14 gauge
LSSU models provide uplift capacity and can be field sloped and/or skewed to 45°. Web stiffeners required when used with TJI® Joists; cut web stiffener to match angle on sloped conditions.

SUR/L, SUR/LI – 16 gauge
HSUR/L – 14 gauge
All models are skewed 45°. Normally accommodates a 40° - 50° skew. The installation of these hangers does not require a beveled end cut.

DOUBLE TJI® JOISTS – Canadian/Factored Resistance (lbs)



Joist Height	Top Flange						Face Mount						45° Skew								
	Model	B Dim	Nails		Uplift (115)	Download	Model	B Dim	Nails		Uplift (115)	Download	Model	B Dim	Nails		Uplift (115)	Download			
			Header	Joist					Header	Joist					Header	Joist			Header	Joist	
Double TJI® 110																			Joist Width = 3 1/2"		
9 1/2	MIT49.5	2 1/2	8-16d	2-10dx1 1/2	535	3480	2415	LF359	2	10-10d	2-#8x1 1/4 WS	100	2525	2155	SUR/L410	2 3/8	14-16d	6-16d	1975	4065	2875
11 7/8	MIT411.88	2 1/2	8-16d	2-10dx1 1/2	535	3480	2415	LF3511	2	12-10d	2-#8x1 1/4 WS	100	2880	2270	SUR/L410	2 3/8	14-16d	6-16d	1975	4065	2875
14	MIT414	2 1/2	8-16d	2-10dx1 1/2	535	3480	2415	LF3514	2	14-10d	2-#8x1 1/4 WS	100	3235	2385	SUR/L414	2 1/2	18-16d	8-16d	2175	4095	2895
Double TJI® 210																			Joist Width = 4 1/8"		
9 1/2	MIT4.28/9.5	2 1/2	8-16d	2-10dx1 1/2	535	3480	2415	MIU4.28/9	2 1/2	16-16d	2-10dx1 1/2	375	4550	3215	HSUR/L4.28/9	3	12-16d	2-10dx1 1/2	275	2995	2350
11 7/8	MIT4.28/11.88	2 1/2	8-16d	2-10dx1 1/2	535	3480	2415	MIU4.28/11	2 1/2	20-16d	2-10dx1 1/2	375	4550	3215	HSUR/L4.28/11	3	16-16d	2-10dx1 1/2	275	4195	2965
14	MIT4.28/14	2 1/2	8-16d	2-10dx1 1/2	535	3480	2415	MIU4.28/14	2 1/2	22-16d	2-10dx1 1/2	375	4930	3485	HSUR/L4.28/14	3	16-16d	2-10dx1 1/2	275	4195	2965
16	LBV4.28/16	2 1/2	10-16d	2-10dx1 1/2	435	3905	3125	MIU4.28/16	2 1/2	24-16d	2-10dx1 1/2	375	4930	3485	HSUR/L4.28/16	3	16-16d	2-10dx1 1/2	275	4195	2965
Double TJI® 230																			Joist Width = 4 5/8"		
9 1/2	MIT359.5-2	2 1/2	8-16d	2-10dx1 1/2	535	3480	2415	MIU4.75/9	2 1/2	16-16d	2-10dx1 1/2	375	4550	3215	HSUR/L4.75/9	2 3/4	12-16d	2-10dx1 1/2	275	2995	2350
11 7/8	MIT3511.88-2	2 1/2	8-16d	2-10dx1 1/2	535	3480	2415	MIU4.75/11	2 1/2	20-16d	2-10dx1 1/2	375	4550	3215	HSUR/L4.75/11	2 3/4	16-16d	2-10dx1 1/2	275	4195	2965
14	MIT3514-2	2 1/2	8-16d	2-10dx1 1/2	535	3480	2415	MIU4.75/14	2 1/2	22-16d	2-10dx1 1/2	375	4930	3485	HSUR/L4.75/14	2 3/4	20-16d	2-10dx1 1/2	275	4195	2965
16	MIT4.75/16	2 1/2	8-16d	2-10dx1 1/2	535	3480	2415	MIU4.75/16	2 1/2	24-16d	2-10dx1 1/2	375	4930	3485	HSUR/L4.75/16	2 3/4	24-16d	2-10dx1 1/2	275	4195	2965
Double TJI® 360																			Joist Width = 4 5/8"		
9 1/2	MIT359.5-2	2 1/2	8-16d	2-10dx1 1/2	535	3480	2415	MIU4.75/9	2 1/2	16-16d	2-10dx1 1/2	375	4550	3215	HSUR/L4.75/9	2 3/4	12-16d	2-10dx1 1/2	275	2995	2350
11 7/8	MIT3511.88-2	2 1/2	8-16d	2-10dx1 1/2	535	3480	2415	MIU4.75/11	2 1/2	20-16d	2-10dx1 1/2	375	4550	3215	HSUR/L4.75/11	2 3/4	16-16d	2-10dx1 1/2	275	4195	2965
14	MIT3514-2	2 1/2	8-16d	2-10dx1 1/2	535	3480	2415	MIU4.75/14	2 1/2	22-16d	2-10dx1 1/2	375	4930	3485	HSUR/L4.75/14	2 3/4	20-16d	2-10dx1 1/2	275	4195	2965
16	MIT4.75/16	2 1/2	8-16d	2-10dx1 1/2	535	3480	2415	MIU4.75/16	2 1/2	24-16d	2-10dx1 1/2	375	4930	3485	HSUR/L4.75/16	2 3/4	24-16d	2-10dx1 1/2	275	4195	2965
18	LBV4.75/18	2 1/2	10-16d	2-10dx1 1/2	435	3905	3125	MIU4.75/18	2 1/2	26-16d	2-10dx1 1/2	375	4930	3485	HSUR/L4.75/18	2 3/4	24-16d	2-10dx1 1/2	275	4195	2965
20	LBV4.75/20	2 1/2	10-16d	2-10dx1 1/2	435	3905	3125	MIU4.75/20	2 1/2	28-16d	2-10dx1 1/2	375	4930	3485	HSUR/L4.75/20	2 3/4	24-16d	2-10dx1 1/2	275	4195	2965
Double TJI® 560																			Joist Width = 7"		
9 1/2	B7.12/9.5	2 1/2	14-16d	6-16d	1650	5940	3910	HU410-2	2 1/2	14-16d	6-16d	1975	5780	4210	HU410-2X ²	2 1/2	14-16d	6-16d	1480	3755	2765
11 7/8	B7.12/11.88	2 1/2	14-16d	6-16d	1650	5940	3910	HU412-2	2 1/2	16-16d	6-16d	1975	5780	4210	HU412-2X ²	2 1/2	16-16d	6-16d	1480	3755	2765
14	B7.12/14	2 1/2	14-16d	6-16d	1650	5940	3910	HU414-2	2 1/2	20-16d	8-16d	2635	5780	4670	HU414-2X ²	2 1/2	20-16d	8-16d	1975	3755	3035
16	B7.12/16	2 1/2	14-16d	6-16d	1650	5940	3910	HU414-2	2 1/2	20-16d	8-16d	2635	5780	4670	HU414-2X ²	2 1/2	20-16d	8-16d	1975	3755	3035
18	B7.12/18	2 1/2	14-16d	6-16d	1650	5940	3910	HU414-2	2 1/2	20-16d	8-16d	2635	5780	4670	HU414-2X ²	2 1/2	20-16d	8-16d	1975	3755	3035
20	B7.12/20	2 1/2	14-16d	6-16d	1650	5940	3910	HU414-2	2 1/2	20-16d	8-16d	2635	5780	4670	HU414-2X ²	2 1/2	20-16d	8-16d	1975	3755	3035

1. Shaded hangers require web stiffeners at joist ends. Web stiffeners may be required by others for non-shaded hangers.
2. Skewed option must be special ordered. Specify skew angle and direction (e.g. HU46-2X SKR45°).
3. LSSU4.12, LSU5.12, and LSU3510-2 are field sloped only. Skewed option must be special ordered. Specify skew angle.

4. THAI hangers require a minimum of 4 top and 2 face nails installed. THAI-2 must be special ordered. Specify width between 3 1/8" and 5 1/8".
5. See page 2, note 2 for header definitions.
6. WS = wood screw.

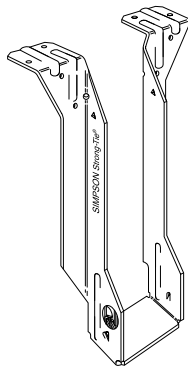

MIT

MIT – 16 gauge
The MIT's Positive Angle Nailing helps minimize splitting of the TJI® Joists' bottom flange. Features uplift capacity and extended seat design (to allow installation of slightly undercut joists).

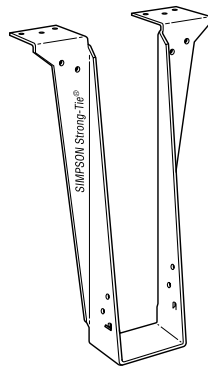

LBV

LBV – 14 gauge
The LBV is designed especially for use with multiple ply headers 1 1/2" to 1 3/4" thick, and may be used for weld-on applications.

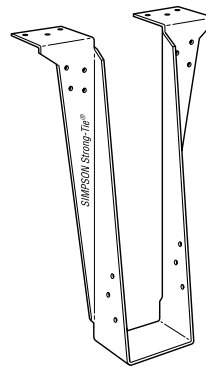

B

B – 12 gauge
The B series offers versatility for TJI® Joists and SCL lumber. Enhanced load capacity widens the range of applications for these hangers.

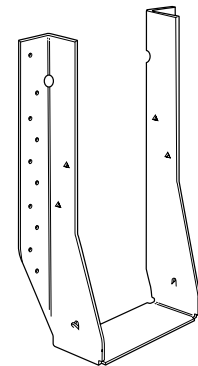

MIU

MIU – 16 gauge
The MIU series features 16 gauge steel and extra nailing for higher loads than the LF.

DOUBLE TJI® JOISTS – Canadian/Factored Resistance (lbs)



Joist Height	Adjustable Height								Field Slope & Skew						
	Model	B Dim	Nails			Uplift (115)	Download		Model	B Dim	Nails		Uplift (115)	Download	
			Header		Joist		DF	SPF			Header	Joist		DF	SPF
			Top	Face											
Double TJI® 110															
Joist Width = 3½"															
9½	THAI422	2¼	4-10d	2-10d	2-10dx1½	—	2740	2075	LSSU410	3½	14-16d	12-10dx1½	1725	3055	2160
11⅞	THAI422	2¼	4-10d	2-10d	2-10dx1½	—	2740	2075	LSSU410	3½	14-16d	12-10dx1½	1725	3055	2160
14	THAI422	2¼	4-10d	2-10d	2-10dx1½	—	2740	2075	LSSU410	3½	14-16d	12-10dx1½	1725	3055	2160
Double TJI® 210															
Joist Width = 4⅛"															
9½	THAI-2 ⁴	2½	4-10d	2-10d	2-10dx1½	—	2935	2935	LSU4.28 ³	3½	24-16d	16-10dx1½	1960	3765	2665
11⅞	THAI-2 ⁴	2½	4-10d	2-10d	2-10dx1½	—	2935	2935	LSU4.28 ³	3½	24-16d	16-10dx1½	1960	3765	2665
14	THAI-2 ⁴	2½	4-10d	2-10d	2-10dx1½	—	2935	2935	LSU4.28 ³	3½	24-16d	16-10dx1½	1960	3765	2665
16	See Canadian <i>Wood Construction Connectors</i> catalogue for hanger selection.								See Canadian <i>Wood Construction Connectors</i> catalogue for hanger selection.						
Double TJI® 230															
Joist Width = 4⅝"															
9½	THAI-2 ⁴	2½	4-10d	2-10d	2-10dx1½	—	2935	2935	LSU3510-2 ³	3½	24-16d	16-10dx1½	1960	3765	2665
11⅞	THAI-2 ⁴	2½	4-10d	2-10d	2-10dx1½	—	2935	2935	LSU3510-2 ³	3½	24-16d	16-10dx1½	1960	3765	2665
14	THAI-2 ⁴	2½	4-10d	2-10d	2-10dx1½	—	2935	2935	LSU3510-2 ³	3½	24-16d	16-10dx1½	1960	3765	2665
16	See Canadian <i>Wood Construction Connectors</i> catalogue for hanger selection.								See Canadian <i>Wood Construction Connectors</i> catalogue for hanger selection.						
Double TJI® 360															
Joist Width = 4⅞"															
9½	THAI-2 ⁴	2½	4-10d	2-10d	2-10dx1½	—	2935	2935	LSU3510-2 ³	3½	24-16d	16-10dx1½	1960	3765	2665
11⅞	THAI-2 ⁴	2½	4-10d	2-10d	2-10dx1½	—	2935	2935	LSU3510-2 ³	3½	24-16d	16-10dx1½	1960	3765	2665
14	THAI-2 ⁴	2½	4-10d	2-10d	2-10dx1½	—	2935	2935	LSU3510-2 ³	3½	24-16d	16-10dx1½	1960	3765	2665
16	See Canadian <i>Wood Construction Connectors</i> catalogue for hanger selection.								See Canadian <i>Wood Construction Connectors</i> catalogue for hanger selection.						
18															
20															
Double TJI® 560															
Joist Width = 7"															
See Canadian <i>Wood Construction Connectors</i> catalogue for hanger selection.								See Canadian <i>Wood Construction Connectors</i> catalogue for hanger selection.							

1. See notes on page 6.

Specified Nail	CSA 086-01 Nail
8d	2½" common wire
10d	3" common wire
16d	3½" common wire

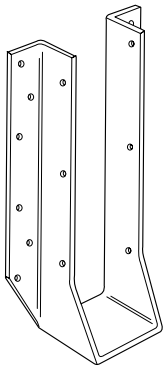

HU

HU – 14 gauge
The HU series features uplift capacity and a large selection of sizes and load ranges. HU hangers have triangle holes that can be filled for increased loads. Web stiffeners required when used with TJI® Joists.

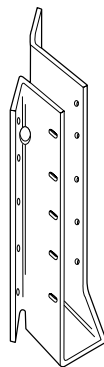

SUL

SUR/L – 16 gauge
HSUR/L – 14 gauge
All models are skewed 45°. Normally accommodates a 40°- 50° skew. The installation of these hangers does not require a beveled end cut.

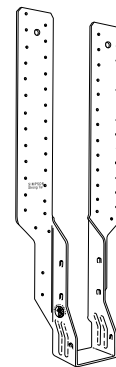

THAI

THAI – 18 gauge
THAI-2 – 14 gauge
This hanger has extra long straps and can be field-formed to give height adjustability and top flange hanger convenience. Positive angle nailing helps minimize splitting of the TJI® Joist's bottom flange. Minimum nailing is shown in the table above. Strap must be field-formed over the top of the header by a minimum of 2½". Web stiffeners required when used with TJI® Joists.

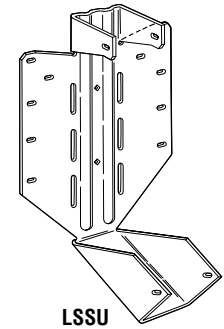

LSSU

LSSU/LSSUI – 18 gauge
LSSU210-2, LSSU410 – 16 gauge
LSU – 14 gauge
LSSU models provide uplift capacity and can be field sloped and/or skewed to 45°. Web stiffeners required when used with TJI® Joists.

BEAMS and HEADERS – Canadian/Factored Resistance (lbs)



Joist Height	Top Flange								Face Mount					
	Model	B Dim	Nails		Uplift (115)	Download			Model	B Dim	Nails		Uplift (115)	DF Download
			Header	Joist		LVL	PSL	LSL			Header	Joist		
1 3/4" Microllam® LVL or Parallam® PSL or TimberStrand® LSL														
7 1/4	LBV1.81/7.25	3	10-16d	2-10dx1 1/2	435	3905	4410	4630	HU7	2 1/2	12-16d	4-10dx1 1/2	1085	3775
9 1/4	LBV1.81/9.25	3	10-16d	2-10dx1 1/2	435	3905	4410	4630	HU7	2 1/2	12-16d	4-10dx1 1/2	1085	3775
	WPU1.81/9.25	4	7-16d	6-10dx1 1/2	1085	6825	7085	5980	HUS1.81/10	3	30-16d	10-16d	5480	7130
9 1/2	MIT9.5	2 1/2	8-16d	2-10dx1 1/2	535	3550	3025	3465	HU9	2 1/2	18-16d	6-10dx1 1/2	1630	4970
	LBV1.81/9.5	3	10-16d	2-10dx1 1/2	435	3905	4410	4630	HUS1.81/10	3	30-16d	10-16d	5480	7130
11 1/4	LBV1.81/11.25	3	10-16d	2-10dx1 1/2	435	3905	4410	4630	HU11	2 1/2	22-16d	6-10dx1 1/2	1630	4970
	WPU1.81/11.25	4	7-16d	6-10dx1 1/2	1085	6825	7085	5980	HUS1.81/10	3	30-16d	10-16d	5480	7130
11 7/8	MIT11.88	2 1/2	8-16d	2-10dx1 1/2	535	3550	3025	3465	HU11	2 1/2	22-16d	6-10dx1 1/2	1630	4970
	BA1.81/11.88	3	16-16d	8-10dx1 1/2	1915	6490	7075	6185	HUS1.81/10	3	30-16d	10-16d	5480	7130
14	MIT1.81/14	2 1/2	8-16d	2-10dx1 1/2	535	3550	3205	3465	HU14	2 1/2	28-16d	8-10dx1 1/2	2175	5445
	LBV1.81/14	3	10-16d	2-10dx1 1/2	435	3905	4410	4630	HUS1.81/10	3	30-16d	10-16d	5480	7130
2 Ply 1 3/4" or 3 1/2" Microllam® LVL or Parallam® PSL or TimberStrand® LSL														
5 1/2	WP3.56/5.5	2 1/2	2-16d	2-10dx1 1/2	—	5950	5430	5980	HHUS46	3	14-16d	6-16d	2920	7335
7 1/4	LBV3.56/7.25	2 1/2	10-16d	2-10dx1 1/2	435	3905	4410	4630	HHUS48	3	22-16d	8-16d	3765	8945
9 1/4	LBV3.56/9.25	2 1/2	10-16d	2-10dx1 1/2	435	3905	4410	4630	HHUS410	3	30-16d	10-16d	5480	9860
	HB3.56/9.25	3 1/2	22-16d	10-16d	3300	9525	9240	10475	HGUS410	4	46-16d	16-16d	6840	14645
9 1/2	LBV3.56/9.5	2 1/2	10-16d	2-10dx1 1/2	435	3905	4410	4630	HHUS410	3	30-16d	10-16d	5480	9860
	HB3.56/9.5	3 1/2	22-16d	10-16d	3300	9525	9240	10475	HGUS410	4	46-16d	16-16d	6840	14645
11 1/4	B3.56/11.25	2 1/2	14-16d	6-16d	1650	6490	5230	6185	HHUS410	3	30-16d	10-16d	5480	9860
	HB3.56/11.25	3 1/2	22-16d	10-16d	3300	9525	9240	10475	HGUS412	4	56-16d	20-16d	7640	14995
11 7/8	BA3.56/11.88	3	16-16d	8-10dx1 1/2	1915	6490	7075	6185	HHUS410	3	30-16d	10-16d	5480	9860
	HB3.56/11.88	3 1/2	22-16d	10-16d	3300	9525	9240	10475	HGUS412	4	56-16d	20-16d	7640	14995
14	BA3.56/14	3	16-16d	8-10dx1 1/2	1915	6490	7075	6185	HHUS410	3	30-16d	10-16d	5480	9860
	SCL3.62/14	4	6-16d	6-16d	1980	15850	15855	—	HGUS414	4	66-16d	22-16d	10130	16400
16	BA3.56/16	3	16-16d	8-10dx1 1/2	1915	6490	7075	6185	HGUS414	4	66-16d	22-16d	10130	16400
	SCL3.62/16	4	6-16d	6-16d	1980	15850	15855	—	HGUS414	4	66-16d	22-16d	10130	16400
18	HB3.56/18	3 1/2	22-16d	10-16d	3300	9525	9240	10475	HGUS414	4	66-16d	22-16d	10130	16400
	SCL3.62/18	5	12-16d	12-16d	3960	21600	20915	—	HGUS414	4	66-16d	22-16d	10130	16400
18 3/4	GLTV3.56/18.75	5	10-16d	6-16d	1980	10890	10745	8590	HGUS414	4	66-16d	22-16d	10130	16400
	SCL3.62/18.75	5	12-16d	12-16d	3960	21600	20915	—	HGUS414	4	66-16d	22-16d	10130	16400
19	GLTV3.56/19	5	10-16d	6-16d	1980	10890	10745	8590	HGUS414	4	66-16d	22-16d	10130	16400
	SCL3.62/19	5	12-16d	12-16d	3960	21600	20915	—	HGUS414	4	66-16d	22-16d	10130	16400

- Other load durations may apply, see current Canadian Limit States catalogue for allowable increases.
- If supporting member is multiple piles of 1 3/4" Parallam® PSL, factored resistance load is 9970 lbs. for GLTV.
- When ordering HGU or HHGU specify height.
- Download for face mount hangers is based on Douglas Fir headers.

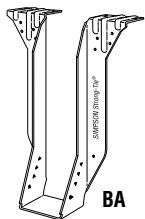

BA – 14 gauge
The BA series offers versatility for TJI® Joists and SCL Lumber. Enhanced load capacity widens the range of applications for these hangers.

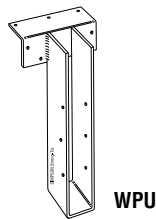

W, WI – Top flange – 12 gauge; Stirrup – 12 gauge
WP, WPI, WPU – Top flange – 7 gauge; Stirrup – 12 gauge
HWU – Top flange – 3 gauge; Stirrup – 10 gauge
This welded series offers the greatest design flexibility and versatility, and a large selection of sizes. Suitable for welded and nailer applications, and modifications including slopes and skews.

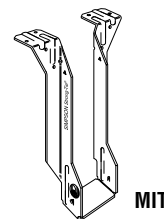

MIT – 16 gauge
The MIT's Positive Angle Nailing helps minimize splitting of the TJI® Joist's bottom flange. Features uplift capacity and extended seat design (to allow installation of slightly undercut joists).

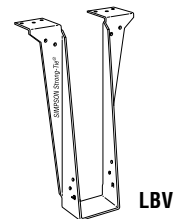

LBV – 14 gauge
The LBV is designed especially for use with multiple ply headers 1 1/2" to 1 3/4" thick, and may be used for weld-on applications.

BEAMS and HEADERS – Canadian/Factored Resistance (lbs)



Joist Height	Top Flange								Face Mount					
	Model	B Dim	Nails		Uplift (115)	Download			Model	B Dim	Nails		Uplift (115)	DF Download
			Header	Joist		LVL	PSL	LSL			Header	Joist		
3 Ply 1 3/4" or 5 1/4" Microllam® LVL or Parallam® PSL or TimberStrand® LSL														
7 1/4	WPU5.50/7.25	3	7-16d	6-10d	1085	6825	7085	5980	HGU5.50/8	4	36-16d	12-16d	6070	12980
9 1/4	HB5.50/9.25	3 1/2	22-16d	10-16d	3300	9525	9240	10475	HHU5.50/10	3	30-16d	10-16d	5480	9860
	GLTV5.50/9.25	5	10-16d	6-16d	1980	10890	10745	8590	HGU5.50/10	4	46-16d	16-16d	6840	14645
9 1/2	HB5.50/9.5	3 1/2	22-16d	10-16d	3300	9525	9240	10475	HHU5.50/10	3	30-16d	10-16d	5480	9860
	SCL5.37/9.5	4	6-16d	6-16d	1980	15850	15855	—	HGU5.50/10	4	46-16d	16-16d	6840	14645
11 1/4	HB5.50/11.25	3 1/2	22-16d	10-16d	3300	9525	9240	10475	HHU5.50/10	3	30-16d	10-16d	5480	9860
	GLTV5.50/11.25	5	10-16d	6-16d	1980	10890	10745	8590	HGU5.50/12	4	56-16d	20-16d	7640	14995
11 7/8	HB5.50/11.88	3 1/2	22-16d	10-16d	3300	9525	9240	10475	HHU5.50/10	3	30-16d	10-16d	5480	9860
	SCL5.37/11.88	5	12-16d	12-16d	3960	21600	20915	—	HGU5.50/12	4	56-16d	20-16d	7640	14995
14	HB5.50/14	3 1/2	22-16d	10-16d	3300	9525	9240	10475	HHU5.50/10	3	30-16d	10-16d	5480	9860
	SCL5.37/14	5	12-16d	12-16d	3960	21600	20915	—	HGU5.50/14	4	66-16d	22-16d	10130	16400
16	HGLTV5.516	6	18-16d	6-16d	1980	15365	11325	13795	HGU5.50/14	4	66-16d	22-16d	10130	16400
	SCL5.37/16	6	10-16d	12-16d	3300	29000	27350	—	HGU5.50-SDS ³	5 1/4	36-SDS 1/4x2 1/2	24-SDS 1/4x2 1/2	10490	20320
18	SCL5.37/18	6	10-16d	12-16d	3300	29000	27350	—	HGU5.50/14	4	66-16d	22-16d	10130	16400
									HGU5.50-SDS ³	5 1/4	36-SDS 1/4x2 1/2	24-SDS 1/4x2 1/2	10490	20320
18 3/4	SCL5.37/18.75	6	10-16d	12-16d	3300	29000	27350	—	HGU5.50/14	4	66-16d	22-16d	10130	16400
									HGU5.50-SDS ³	5 1/4	36-SDS 1/4x2 1/2	24-SDS 1/4x2 1/2	10490	20320
19	SCL5.37/19	6	10-16d	12-16d	3300	29000	27350	—	HGU5.50/14	4	66-16d	22-16d	10130	16400
									HGU5.50-SDS ³	5 1/4	36-SDS 1/4x2 1/2	24-SDS 1/4x2 1/2	10490	20320
4 Ply 1 3/4" or 7" Microllam® LVL or Parallam® PSL or TimberStrand® LSL														
9 1/4	HB7.12/9.25	3 1/2	22-16d	10-16d	3300	9525	9240	10475	HHU7.25/10	3 9/16	30-16d	10-16d	5480	10780
	GLTV49.25-2	5	10-16d	6-16d	1980	10890	10745	8590	HGU7.25/10	4	46-16d	16-16d	6840	15760
9 1/2	HB7.12/9.5	3 1/2	22-16d	10-16d	3300	9525	9240	10475	HHU7.25/10	3 9/16	30-16d	10-16d	5480	10780
	SCL7.25/9.5	4	6-16d	6-16d	1980	15850	15855	—	HGU7.25/10	4	46-16d	16-16d	6840	15760
11 1/4	GLTV411.25-2	5	10-16d	6-16d	1980	10890	10745	8590	HHU7.25/10	3 9/16	30-16d	10-16d	5480	10780
	HGLTV411.25-2	6	18-16d	6-16d	1980	15365	11325	13795	HGU7.25/12	4	56-16d	20-16d	7640	16110
11 7/8	GLTV411.88-2	5	10-16d	6-16d	1980	10890	10745	8590	HHU7.25/10	3 9/16	30-16d	10-16d	5480	10780
	SCL7.25/11.88	5	12-16d	12-16d	3960	21600	20915	—	HGU7.25/12	4	56-16d	20-16d	7640	16110
14	SCL7.25/14	5	12-16d	12-16d	3960	21600	20915	—	HGU7.25/14	4	66-16d	22-16d	10130	18200
									HGU7.25-SDS ³	5 1/4	36-SDS 1/4x2 1/2	24-SDS 1/4x2 1/2	10490	20320
16	SCL7.25/16	6	10-16d	12-16d	3300	29000	27350	—	HGU7.25/14	4	66-16d	22-16d	10130	18200
									HHGU7.25-SDS ³	5 1/4	44-SDS 1/4x2 1/2	28-SDS 1/4x2 1/2	13075	26665
18	SCL7.25/18	6	10-16d	12-16d	3300	29000	27350	—	HGU7.25/14	4	66-16d	22-16d	10130	18200
									HHGU7.25-SDS ³	5 1/4	44-SDS 1/4x2 1/2	28-SDS 1/4x2 1/2	13075	26665
18 3/4	SCL7.25/18.75	6	10-16d	12-16d	3300	29000	27350	—	HGU7.25/14	4	66-16d	22-16d	10130	18200
									HHGU7.25-SDS ³	5 1/4	44-SDS 1/4x2 1/2	28-SDS 1/4x2 1/2	13075	26665
19	SCL7.25/19	6	10-16d	12-16d	3300	29000	27350	—	HGU7.25/14	4	66-16d	22-16d	10130	18200
									HHGU7.25-SDS ³	5 1/4	44-SDS 1/4x2 1/2	28-SDS 1/4x2 1/2	13075	26665

1. See footnotes on page 8.

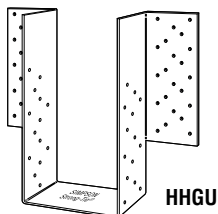

HGU – 7 gauge
HHGU – 3 gauge
 The GU hangers are a high-capacity girder hanger designed for situations where the header and joist are flush at top.

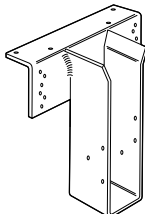

GLTV & HGLTV – Top flange – 3 gauge
 Stirrup – 7 gauge
 This welded series provides high load carrying capacity and design flexibility and versatility. May be sloped, skewed and modified in other ways, and may be welded to steel I-beams. The GLTV may be used on 4x nailers.

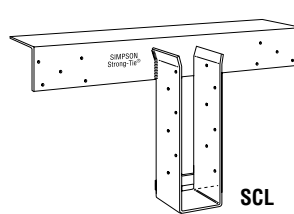

SCL – Top flange – 1/4" or 3/8" hot rolled angle
 Stirrup – 3 gauge
 This series offers high load capacities. The large top flange distributes the load to the carrying member.

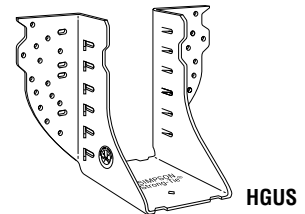

HGU5 – 12 gauge
HHU5 – 14 gauge
 Features double shear nailing for high strength and lowest installed cost due to the reduced nail quantity requirement. Not suitable for use with TJI® Joists.

GENERAL CONNECTOR INSTALLATION



Top Flange Hangers

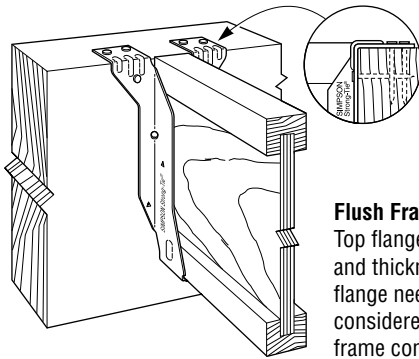

Flush Framing
Top flange configuration and thickness of top flange need to be considered for flush frame conditions.

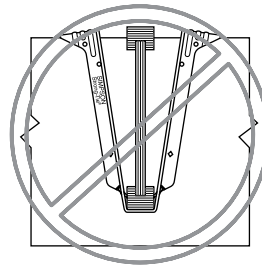

Hanger Over-Spread
If the hanger is over-spread, it can raise the TJI® Joist above the header and may cause uneven surfaces and squeaky floors.

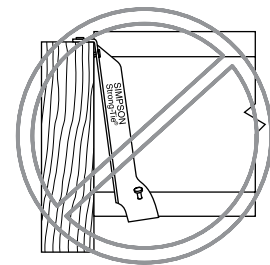

Hanger Not Plumb
A hanger "kicked out" from the header can cause uneven surfaces and squeaky floors.

Wood Nailers

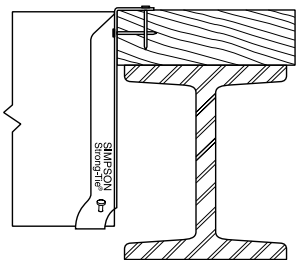

Correct Attachment

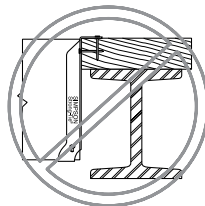

Nailer Too Wide
The loading may cause cross-grain bending. As a general rule, the maximum allowable overhang is 1/4", depending on nailer thickness.

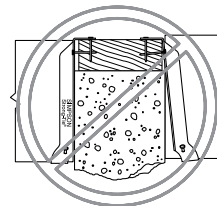

Nailer Too Narrow
A maximum mismatch of 1/8" for normal installations is acceptable.

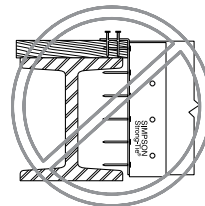

Nailer Too Thin and the wrong hanger for a nailer application.

Nail Hole Shapes

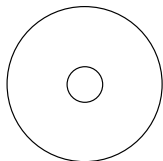

Round Holes
All holes must be filled except for the THAI adjustable height hanger. Refer to load tables for THAI nail quantities.

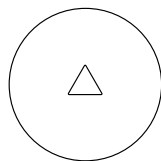

Triangle Holes
Provided on some products in addition to round holes. Round and triangle holes must be filled to achieve the published maximum load value.

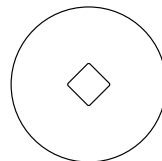

Diamond Holes
Optional holes to temporarily secure connectors to the member during installation.

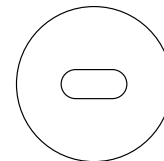

Obround Holes
Used to provide easier nailing access in tight locations. All holes must be filled except for the LSSU hanger when skewed. Refer to load tables for LSSU nail quantities.

Toe Nailed TJI® Joist

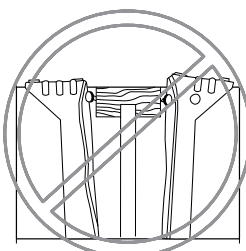

Toe nailing causes squeaks and improper hanger installations. **Do not toe nail TJI® Joists prior to installing either top flange or face mount hangers.**

Double Shear Nailing

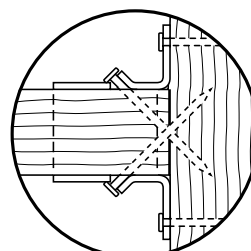

The nail is installed into joist and header, distributing load through two points on each nail for greater strength.

GENERAL CONNECTOR INSTALLATION

IUS Installation Sequence

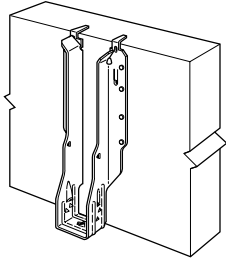

STEP 1
Attach the IUS to the header

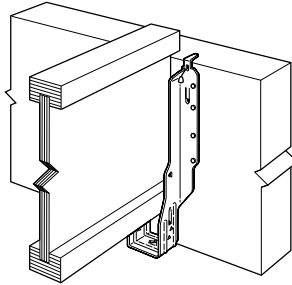

STEP 2
Slide the TJI® Joist into the IUS until it rests above the large teardrop.

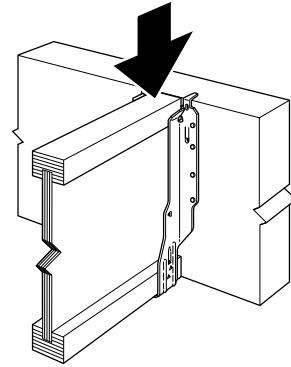

STEP 3
Firmly push or snap TJI® Joist fully into the seat of the IUS.

LT and LF Screw Installation

Use 8 gauge (0.164" diameter) x 1¼" wood screw (#8x1¼") to secure joist to hanger.

To avoid stripping of the bottom chord screw hole, DO NOT over tighten screw.

Use specified screw to seat joist into hanger (required only for LF and LT hangers).

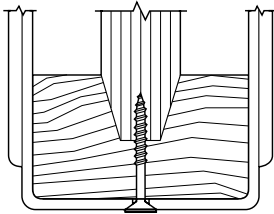

Alternate Uplift Option for IUS

This installation works for TJI® Joists with 1½" or greater depth of bottom flange. Install Simpson's SD8x1.25 tapping screw through the diamond hole in the bottom of the seat.

Model No.	Joist Fasteners	Uplift	
		DF (115)	SPF (115)
IUS	Simpson SD8x1.25 Tapping Screw ¹	250	215

- Any #8x1.25 self-drilling screw may be used.
- Loads are in pounds.

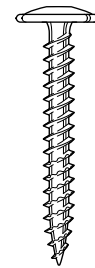

SD8x1.25
(Actual Size)

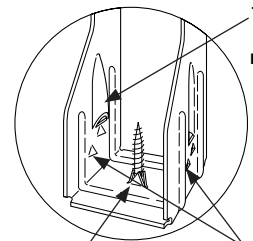

Snap-In Teardrop
No nails required!

IUS

The Strong-Grip™ seat secures I-joists in position without joist nails

Starburst detail allows secure seating of joist.

VPA Installation

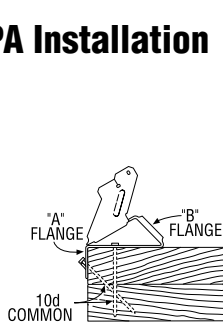

STEP 1
Install top nails and face PAN nails in "A" flange to outside wall top plate.

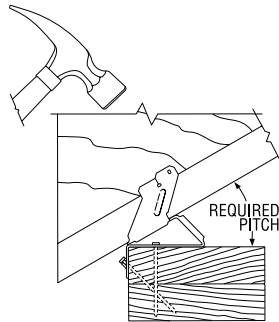

STEP 2
Seat rafter with a hammer, adjusting "B" flange to the required pitch.

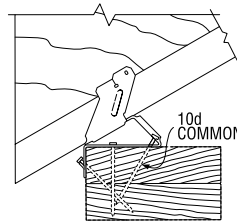

STEP 3
Install "B" flange nails in the obround nail holes, locking the pitch.

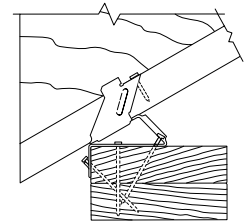

STEP 4
Bend tab with hammer and install nail into tab nail hole. Hammer nail in at approx. 45° angle to limit splitting.

LSSU Installation

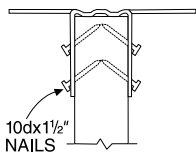

1. Nail hanger to slope-cut joist, installing seat nail first. No bevel necessary for skewed installation.

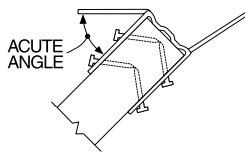

2. Skew flange to form acute angle. Bend other flange back. Bend along the centerline of slots. Bend one time only.

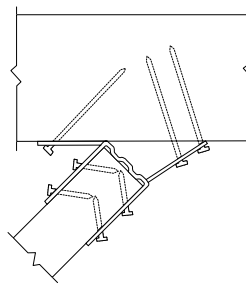

3. Attach hanger to header, acute angle first. Install nails at an angle.

THAI Minimum Nailing

MINIMUM OF 2½" OF TOP FLANGE MATERIAL FOR MINIMUM NAILING CONFIGURATION

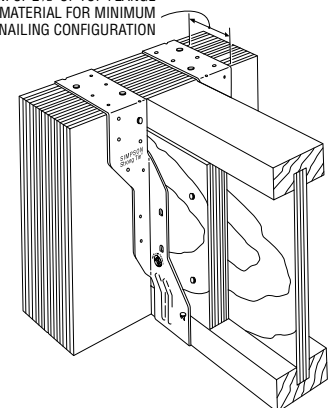

GENERAL CONNECTOR INSTALLATION



TB - Tension Bridging

Joist Height	Joist Spacing (Inches)								
	12	16	19.2	24	30	32	36	42	48
9½	TB20	TB27	TB27	TB30	TB36	TB36	TB42	TB48	TB54
11⅞	TB20	TB27	TB27	TB30	TB36	TB36	TB42	TB48	TB54
14	TB27	TB27	TB27	TB36	TB36	TB42	TB42	TB48	TB54
16	TB27	TB27	TB30	TB36	TB42	TB42	TB42	TB48	TB54

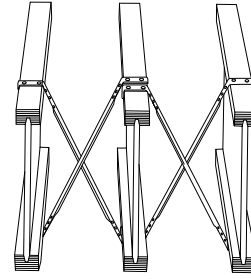

Typical TB Installation

VPA - Variable Pitch Connectors

Joist Width	Model No.	Fasteners		Factored Resistances							
		Top Plate	Rafter	Uplift (115)		Download (100)		Lateral Load (115)			
				DF	SPF	DF	SPF	DF		SPF	
2¼	VPA2.1	9-10d	2-10dx1½	545	390	1785	1785	625	415	615	415
2½	VPA35	9-10d	2-10dx1½	545	390	1785	1785	625	415	615	415
3½	VPA4	11-10d	2-10dx1½	545	390	1785	1785	625	415	615	415

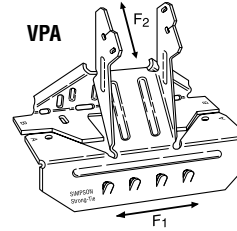

VPA – 18 gauge
This variable pitch connector allows a sloped beam to sit on a top plate without having to notch, birdmouth, bevel, or toe nail. It also provides uplift capacity. Adjustable from 3:12 to 12:12 pitch.

1. VPA's are not appropriate for applications that require more than 2" of bearing, such as intermediate supports.

STRONG-DRIVE® SCREW INSTALLATION FOR LVL

INSTALLATION

- Hex washer head allows for easy driving.
- Built-in reamer and the 4CUT™ tip means no pre-drilling required.
- See illustrations for SDS positioning on different assemblies.
- Install with high-torque, low speed drill (5 amp+).
- Do not over-drive the SDS screws.

DESIGN

- This document uses Microllam® LVL values specified in iLevel® literature.
- Uniform loads in the table represent the capacity of the fasteners. The capacity of the Microllam® beam may be less and should be checked by a qualified designer or with iLevel® literature.
- The designer shall specify the location of all screws (stagger screws on opposite faces). Minimum recommended spacing—Wide Face: end distance 4", edge distance 1½", spacing parallel to grain 4", spacing perpendicular to grain 2½".

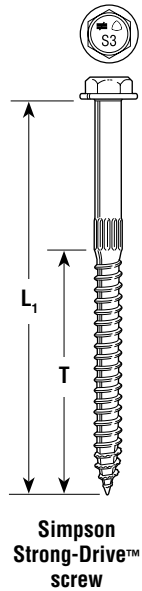

Screw Dimensions

Model	L ₁ (in)	T (in)	Head Stamp
SDS25312	3½	2¼	S3.5
SDS25412	4½	2¾	S4.5
SDS25600	6	3¼	S6

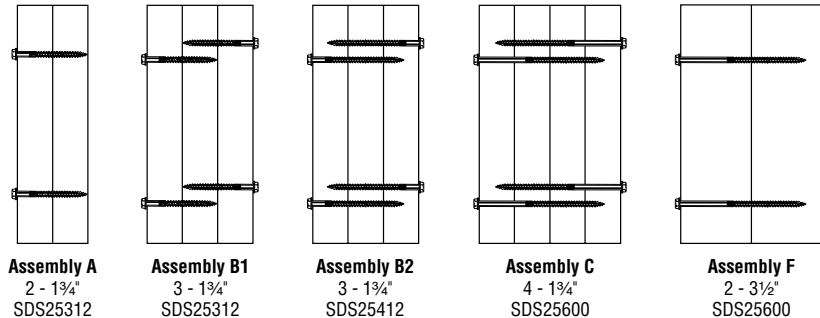

Assembly	SDS Screw Length	Side Member Thickness	Maximum Factored Uniform Load Applied to Outer Member (plf)					
			SDS @12" o/c		SDS @16" o/c		SDS @24" o/c	
Microllam® LVL (SG = 0.50)								
			2-Rows	3-Rows	2-Rows	3-Rows	2-Rows	3-Rows
A	3½	1¼	1220	1830	915	1370	610	915
B1	3½	1¼	915	1370	685	1030	455	685
B2	4½	1¼	1455	2180	1090	1635	725	1090
C	6	1¼	1040	1560	780	1170	520	780
F	6	3½	1220	1830	915	1375	610	915

1. If 7" wide beams are not equally loaded on each side, the load from the lesser side should be at least 25% of the opposite side.
2. Quantity and spacing of screws in table are for each screw head side of the assembly as shown in the Assembly figures above.
3. The design professional shall ensure that adequate lateral bracing is provided to prevent displacement of the beam due to the torsion created by the structural members framing into the side of the beam assembly.

iLevel®, Microllam®, Parallam®, TimberStrand® and TJI® are registered trademarks of Weyerhaeuser.

Refer to the current Canadian Wood Construction Connectors catalogue for General Notes, Warranty Information and other important information, including Terms and Conditions of Sale, Building Code Evaluation listings and Corrosion Resistance.

© 2008 Simpson Strong-Tie Company Inc. • P.O. Box 10789, Pleasanton, CA 94588

CSG-TJCAN09 1/09 exp. 1/11 1/12

800-999-5099
www.strongtie.com



TJI® s31, TJI® s33 & TJI® s47



LIMIT STATES DESIGN



SINGLE TJI® JOISTS – Canadian/Factored Resistance (lbs)

Joist Height	Top Flange							Snap-In						Face Mount							
	Model	B Dim	Fastener Type		Uplift (115)	Down Load		Model	B Dim	Fastener Type		Uplift (115)	Down Load		Model	B Dim	Fastener Type		Uplift (115)	Down Load	
			Header	Joist		DF	SPF			Header	Joist		DF	SPF			Header	Joist		DF	SPF
TJI® s31, TJI® s33																					
Joist Width = 2½"																					
9½	LT259	2	6-10d	1-#8x1¼WS	100	2560	1725	IUS2.56/9.5	2	8-10d	—	105	2385	1700	LF259	2	10-10d	1-#8x1¼WS	100	2525	2155
11½	LT251188	2	6-10d	1-#8x1¼WS	100	2560	1725	IUS2.56/11.88	2	10-10d	—	105	2565	1835	LF2511	2	12-10d	1-#8x1¼WS	100	2880	2270
14	LT2514	2	6-10d	1-#8x1¼WS	100	2560	1725	IUS2.56/14	2	12-10d	—	105	2565	1835	LF2514	2	14-10d	1-#8x1¼WS	100	3235	2385
16	LT2516	2	6-10d	1-#8x1¼WS	100	2560	1725	IUS2.56/16	2	14-10d	—	105	2725	1950	MIU2.56/16	2½	24-16d	2-10dx1½	270	4930	3485
TJI® s47																					
Joist Width = 3½"																					
11½	LT351188	2	6-10d	2-#8x1¼WS	100	2560	1725	IUS3.56/11.88	2	12-10d	—	105	2375	1695	LF3511	2	12-10d	2-#8x1¼WS	100	2880	2270
14	LT3514	2	6-10d	2-#8x1¼WS	100	2560	1725	IUS3.56/14	2	12-10d	—	105	2375	1695	LF3514	2	14-10d	2-#8x1¼WS	100	3235	2385
16	LT3516	2	6-10d	2-#8x1¼WS	100	2560	1725	IUS3.56/16	2	14-10d	—	105	2375	1695	MIU3.56/16	2½	24-16d	2-10dx1½	270	4930	3485
18	MIT418	2½	8-16d	2-10dx1½	380	3480	2415	No IUS Hanger for these sizes						MIU3.56/18	2½	26-16d	2-10dx1½	270	4930	3485	
20	MIT420	2½	8-16d	2-10dx1½	380	3480	2415							MIU3.56/20	2½	28-16d	2-10dx1½	270	4930	3485	

Joist Height	45° Skew							Adjustable Height						Field Slope & Skew							
	Model	B Dim	Fastener Type		Uplift (115)	Down Load		Model	B Dim	Fastener Type		Uplift (115)	Down Load		Model	B Dim	Fastener Type		Uplift (115)	Down Load	
			Header	Joist		DF	SPF			Header	Joist		DF	SPF			Header	Joist		DF	SPF
TJI® s31, TJI® s33																					
Joist Width = 2½"																					
9½	SUR/L2.56/9	3¾	14-16d	2-10dx1½	385	3945	2780	THAI322	2¼	6-10d	2-10dx1½	—	2740	2075	LSSUH310	3½	14-16d	12-10dx1½	1220	2620	1850
11½	SUR/L2.56/11	3¾	16-16d	2-10dx1½	385	3945	2780	THAI322	2¼	6-10d	2-10dx1½	—	2740	2075	LSSUH310	3½	14-16d	12-10dx1½	1220	2620	1850
14	SUR/L2.56/14	3¾	18-16d	2-10dx1½	385	3945	2780	THAI322	2¼	6-10d	2-10dx1½	—	2740	2075	LSSUH310	3½	14-16d	12-10dx1½	1220	2620	1850
16	SUR/L2.56/14	3¾	18-16d	2-10dx1½	385	3945	2780	See Canadian Wood Construction Connectors catalogue for hanger selection.						See Canadian Wood Construction Connectors catalogue for hanger selection.							
TJI® s47																					
Joist Width = 3½"																					
11½	SUR/L410	2½	14-16d	6-16d	1395	4065	2875	THAI422	2¼	6-10d	2-10dx1½	—	2740	2075	LSSU410	3½	14-16d	12-10dx1½	1220	3055	2160
14	SUR/L414	2½	18-16d	8-16d	1555	4095	2895	THAI422	2¼	6-10d	2-10dx1½	—	2740	2075	LSSU410	3½	14-16d	12-10dx1½	1220	3055	2160
16	SUR/L414	2½	18-16d	8-16d	1555	4095	2895	See Canadian Wood Construction Connectors catalogue for hanger selection.						See Canadian Wood Construction Connectors catalogue for hanger selection.							
18	SUR/L414	2½	18-16d	8-16d	1555	4095	2895														
20	SUR/L414	2½	18-16d	8-16d	1555	4095	2895														

1. Shaded hangers require web stiffeners at joist ends. Web stiffeners may be required for non-shaded hangers by I-Joist manufacturer.
2. THAI hangers require a minimum of 4 top and 2 face nails installed.
3. The B Dim is the length of the hanger seat.
4. WS = Wood Screw.

Specified Nail	CSA 086-01 Nail
8d	2½" common wire
10d	3" common wire
16d	3½" common wire

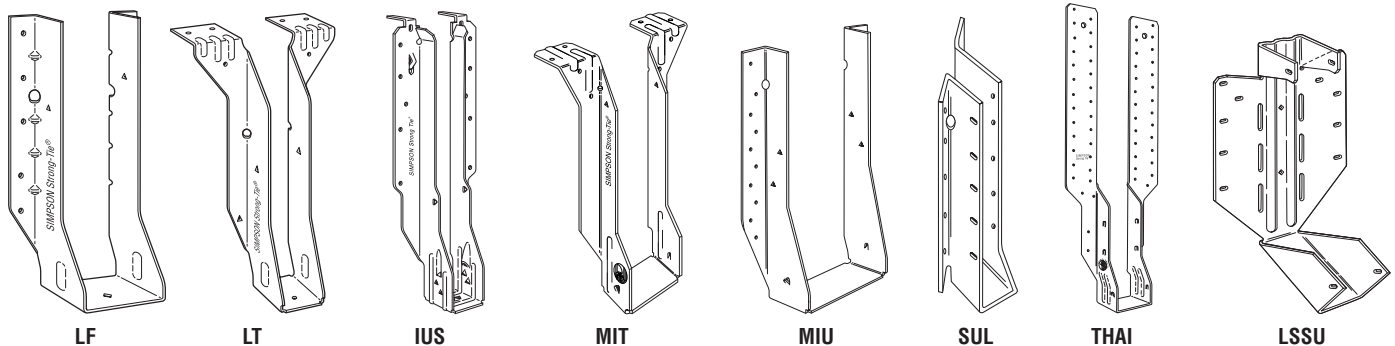



TJI® s31, TJI® s33 & TJI® s47



LIMIT STATES DESIGN



DOUBLE TJI® JOISTS – Canadian/Factored Resistance (lbs)

Joist Height	Top Flange						Face Mount						45° Skew								
	Model	B Dim	Fastener Type		Uplift (115)	Down Load		Model	B Dim	Fastener Type		Uplift (115)	Down Load		Model	B Dim	Fastener Type		Uplift (115)	Down Load	
			Header	Joist		DF	SPF			Header	Joist		DF	SPF			Header	Joist		DF	SPF
Double TJI® s31, TJI® s33																					
Joist Width = 5"																					
9½	MIT39.5-2	2½	8-16d	2-10dx1½	380	3480	2415	MIU5.12/9	2½	16-16d	2-10dx1½	270	4550	3215	HSUR/L5.12/9	2½	12-16d	2-10dx1½	195	2995	2350
11⅞	MIT311.88-2	2½	8-16d	2-10dx1½	380	3480	2415	MIU5.12/11	2½	20-16d	2-10dx1½	270	4550	3215	HSUR/L5.12/11	2½	16-16d	2-10dx1½	195	4195	2965
14	MIT314-2	2½	8-16d	2-10dx1½	380	3480	2415	MIU5.12/14	2½	22-16d	2-10dx1½	270	4930	3485	HSUR/L5.12/14	2½	20-16d	2-10dx1½	195	4195	2965
16	MIT5.12/16	2½	8-16d	2-10dx1½	380	3480	2415	MIU5.12/16	2½	24-16d	2-10dx1½	270	4930	3485	HSUR/L5.12/16	2½	24-16d	2-10dx1½	195	4195	2965
Double TJI® s47																					
Joist Width = 7"																					
11⅞	B7.12/11.88	2½	14-16d	6-16d	1170	5940	3910	HU412-2	2½	22-16d	8-16d	1865	5780	4670	HU412-2X ⁴	2½	22-16d	8-16d	1400	3755	3035
14	B7.12/14	2½	14-16d	6-16d	1170	5940	3910	HU414-2	2½	26-16d	12-16d	2685	7025	5780	HU414-2X ⁴	2½	26-16d	12-16d	2015	4565	3755
16	B7.12/16	2½	14-16d	6-16d	1170	5940	3910	HU414-2	2½	26-16d	12-16d	2685	7025	5780	HU414-2X ⁴	2½	26-16d	12-16d	2015	4565	3755
18	B7.12/18	2½	14-16d	6-16d	1170	5940	3910	HU414-2	2½	26-16d	12-16d	2685	7025	5780	HU414-2X ⁴	2½	26-16d	12-16d	2015	4565	3755
20	B7.12/20	2½	14-16d	6-16d	1170	5940	3910	HU414-2	2½	26-16d	12-16d	2685	7025	5780	HU414-2X ⁴	2½	26-16d	12-16d	2015	4565	3755

Joist Height	Adjustable Height						Field Slope & Skew							
	Model	B Dim	Fastener Type		Uplift (115)	Down Load		Model	B Dim	Fastener Type		Uplift (115)	Down Load	
			Header	Joist		DF	SPF			Header	Joist		DF	SPF
Double TJI® s31, TJI® s33														
Joist Width = 5"														
9½	THAI-2 ²	2½	6-10d	2-10dx1½	—	2935	2935	LSU5.12 ³	3½	24-16d	16-10dx1½	910	2600	1835
11⅞	THAI-2 ²	2½	6-10d	2-10dx1½	—	2935	2935	LSU5.12 ³	3½	24-16d	16-10dx1½	910	2600	1835
14	THAI-2 ²	2½	6-10d	2-10dx1½	—	2935	2935	LSU5.12 ³	3½	24-16d	16-10dx1½	910	2600	1835
16	See Canadian Wood Construction Connectors catalogue for hanger selection.						See Canadian Wood Construction Connectors catalogue for hanger selection.							
Double TJI® s47														
Joist Width = 7"														
11⅞	See Canadian Wood Construction Connectors catalogue for hanger selection.						See Canadian Wood Construction Connectors catalogue for hanger selection.							
14														
16														
18														
20														

1. Shaded hangers require web stiffeners at joist ends. Web stiffeners may be required for non-shaded hangers by I-Joist manufacturer.
2. THAI hangers require a minimum of 4 top and 2 face nails installed. THAI-2 must be special ordered. Specify hanger seat width between 3⅞" and 5⅞".
3. LSU5.12 skew options must be factory ordered.
4. Skew option must be special ordered. Specify skew angle and direction (e.g. HU410-2x, SKR 45°).
5. The B Dim is the length of the hanger seat.

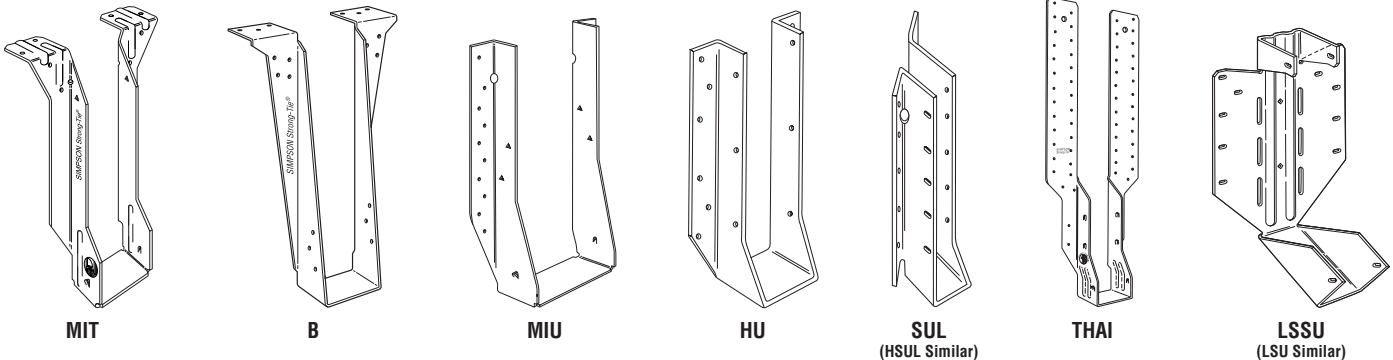

Refer to the current Canadian Wood Construction Connectors catalogue for General Notes, Warranty Information and other important information, including Terms and Conditions of Sale, Building Code Evaluation listings and Corrosion Resistance.